

Codice Prodotto <i>Product Code</i>	9.649.007.20	 Fornito Privo di Lubrificante! Supplied without oil!
Descrizione <i>Description</i>	A-649A	

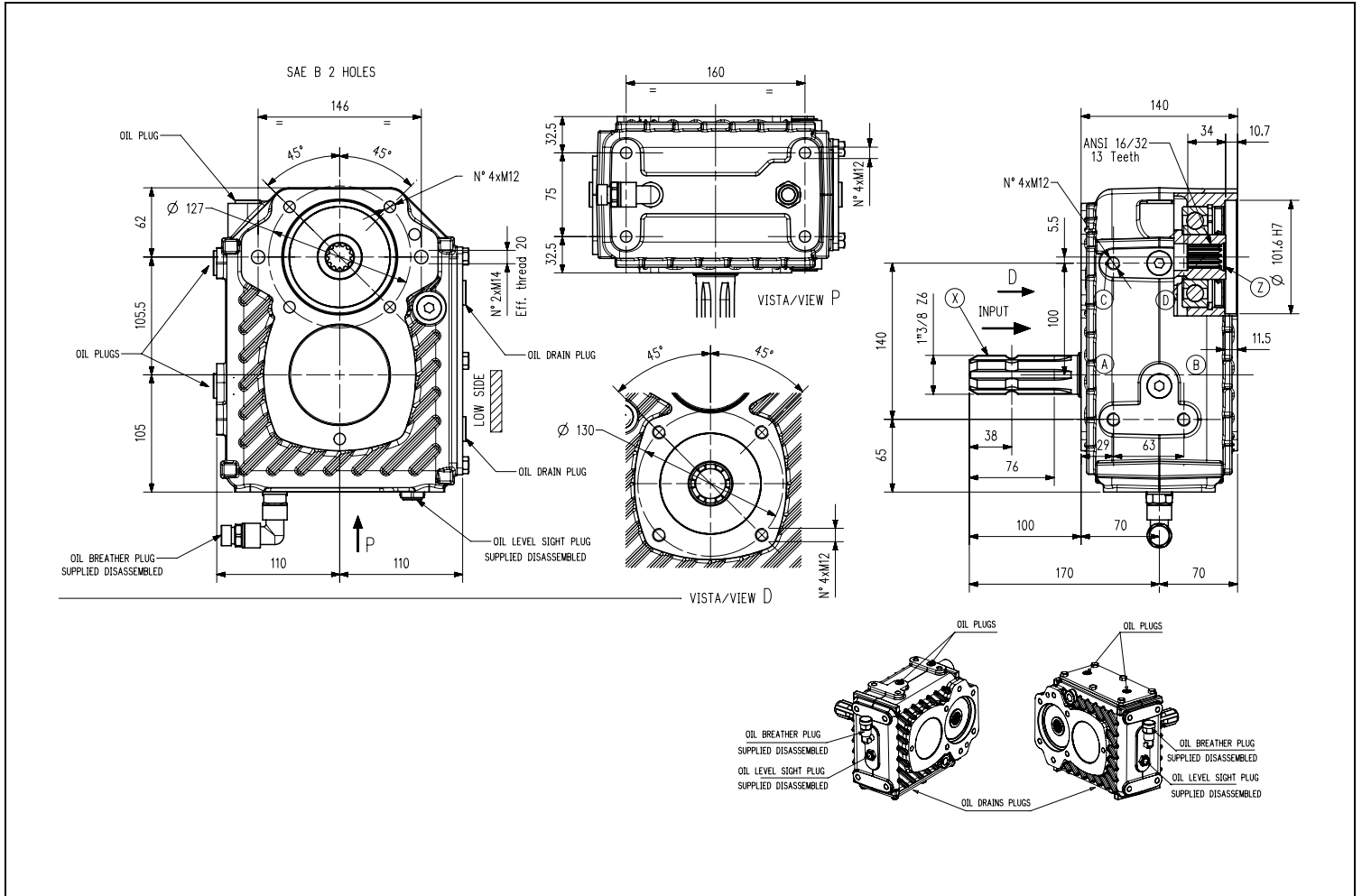
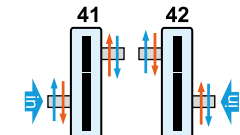
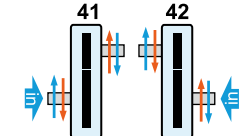

Tipo * Type *	Rapporto Ratio	Giri entrata Input r.p.m.	Potenza entrata Input Power [kW]	Momento Torcente Uscita Output Torque [daNm]	Peso Weight [kg]	Albero Ingresso Input shaft	Sensi di Rotazione Direction of Rotation
M	1:4,23	540	40,4	17,2	25,2	X	
M	1:4,23	1000	55,8	12,4		X	

* Tipo: M= Moltiplicatore di Giri R= Riduttori di Giri O= Rinvio 1:1 RC= Riduttore Cambio di Velocità MC= Moltiplicatore Cambio di Velocità
 * Type: M= Speed Increaser R= Reducer O= Gearbox 1:1 RC= Speed-Change Reducer MC= Speed-Change Increaser